

SensoWash(R) Starck Lite Compact-Unit # 650001012004310

| < 378 mm > |

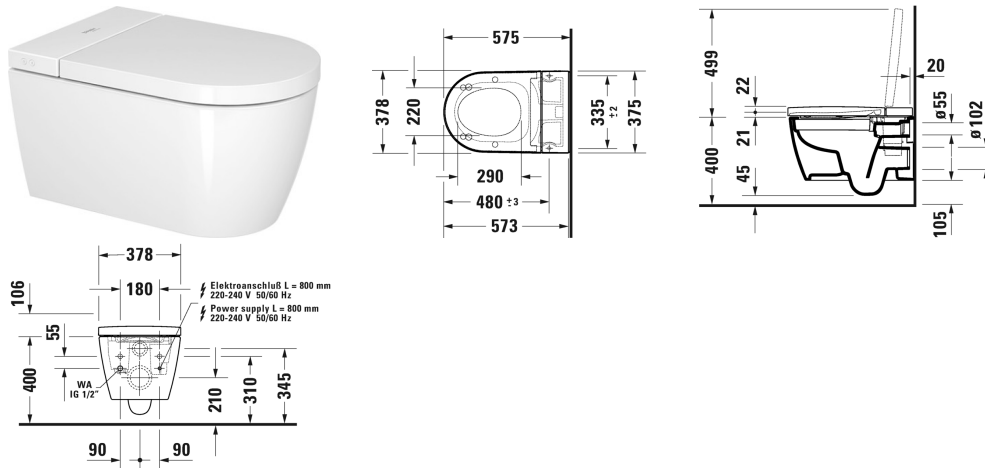

SensoWash(R) Starck Lite Compact-Unit	Dimension	Weight	Order number
rear-, front and oscillating wash, Seat heating, Intelligent energy saving mode, Warm air dryer, individual adjustment of water, air and seat surface temperature as well as nozzle position and jet strength, Automatic drainage in periods of prolonged disuse, Descaling function, night light, rimless, remote control included, washdown model, App operation, self-cleaning wand, Seat/lid material thermoplastic, with concealed connections			
Colors			
00 White Alpin			
Variant			
220-240V 50/60Hz, EN 1717 compliant	378 x 575 mm	32.500 kg	650001012004310
Infobox			
Choose suitable pre-installation kit or connecting set depending on used in-wall carrier			
Suitable spareparts			
Fixing for wall mounted bidet and wall mounted toilet, Ø 12 x 180 mm	Ø 12 x 180 mm		006500
Noise reduction gasket for wall mounted toilet,			005064
Pre-installation kit in combination with SensoWash, for in-wall carrier with horizontal support without shower toilet pre-installation/conduit pipe,			005072
Interface set in combination with SensoWash Starck f, for functional interface with DuraSystem actuator plate A2,			100729
Connecting set in combination with SensoWash Starck f,			100731

SensoWash(R) Starck Lite Compact-Unit # 650001012004310

|< 378 mm >|

All drawings contain the necessary measurements which are subject to standard tolerances. Exact measurements, in particular for customised installation scenarios, can only be taken from the finished ceramic piece.