



Roca

IN-WASH INSPIRA

A803060001

A803060002

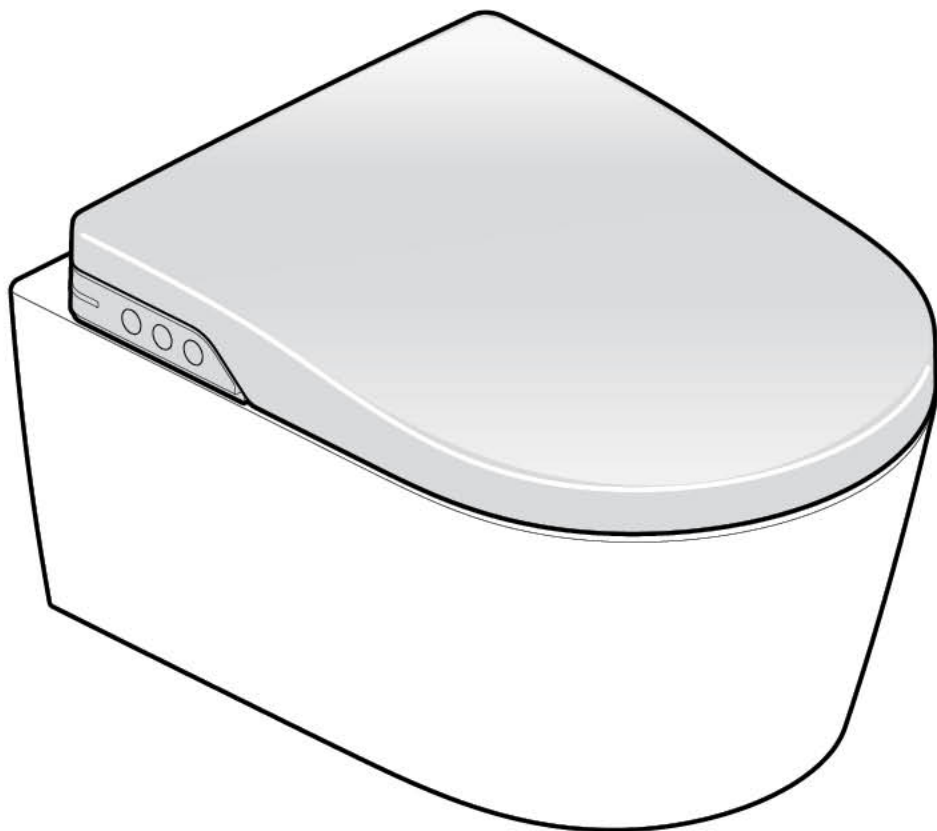

ES / EN

- ES** - Antes de instalar, asegúrese de leer este manual de instalación y la hoja adjunta de precauciones de seguridad. Las piezas deben ser instaladas de acuerdo a las instrucciones.
- No dañar las piezas de la conexión eléctrica.
 - El rango de presión de agua recomendable es de 0,05 MPa - 0,9 MPa. Utilizar el equipo dentro de la presión de agua indicada.
 - La temperatura del suministro de agua debe estar entre 10 - 30°C. Asegúrese de que la temperatura del agua se encuentra dentro de este rango.
 - No utilizar otra manguera de suministro de agua distinta a la que se incluye con el producto.
 - Asegúrese de que el producto está correctamente conectado a una toma de tierra. (Si no existe una una conexión de tierra, existe el riesgo de rotura o fuga eléctrica que puede resultar en un choque eléctrico).
 - Disponga previamente de una toma de corriente adecuada, acorde con la normativa local vigente.
-

- EN** - Before installation, read thoroughly this installation manual and the included safety precautions leaf. Parts must be installed according to the instructions.
- Do not damage the electrical connection parts.
 - The recommended rank of water pressure of the water supply is 0,05 MPa - 0,9 MPa. Use this equipment within the recommended water pressure rank.
 - The temperature of the water supply must be between 10 - 30°C. Make sure the water temperature is between this rank.
 - Do not use a water hose other than the one provided with this product.
 - Make sure that this product is correctly attached to a ground connection. (If the product is not ground-connected, there is a risk of a breaking or electric leak that might result in an electric shock).
 - Prior to the installation, have an adequate electrical outlet available, according to the current local legislation.
-

[mm]

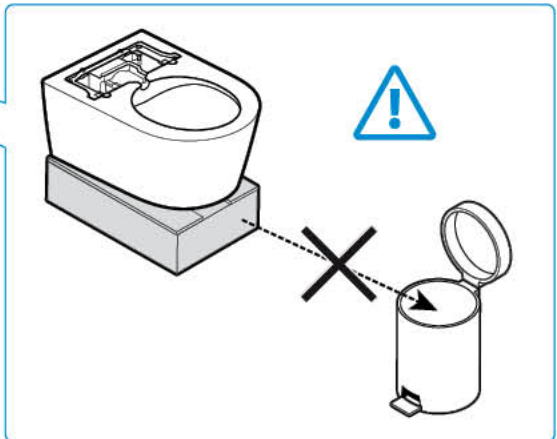
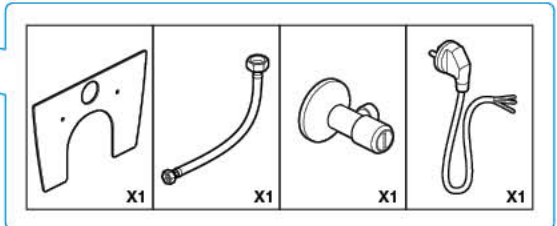
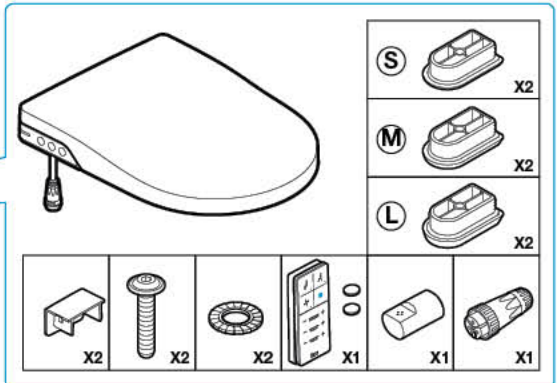
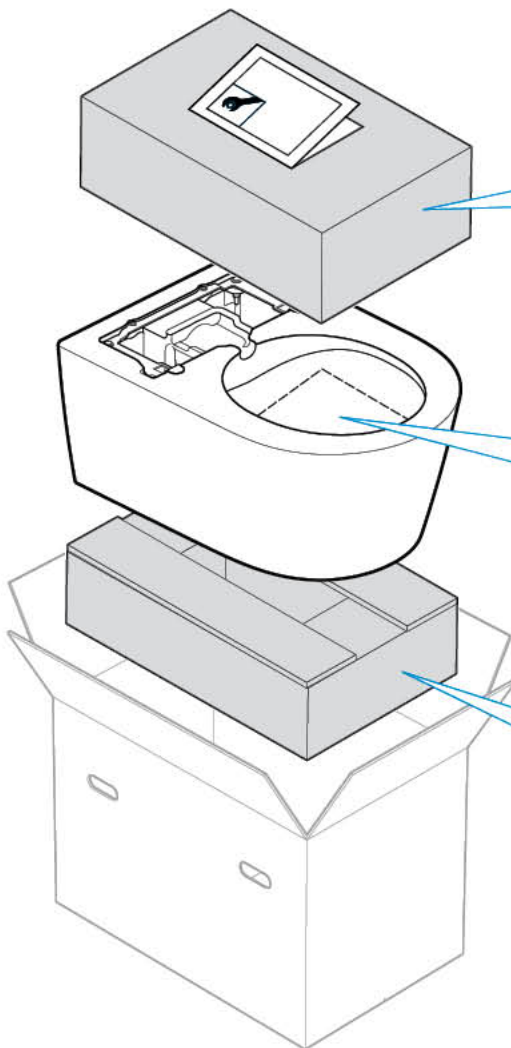
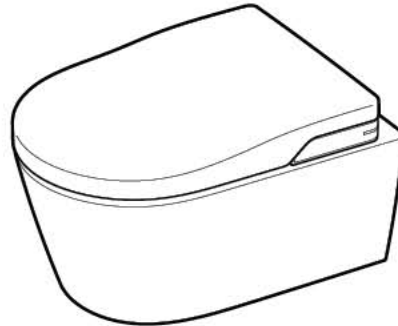
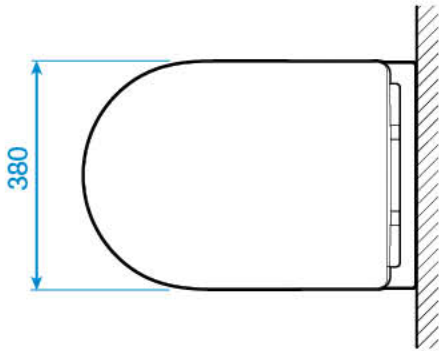
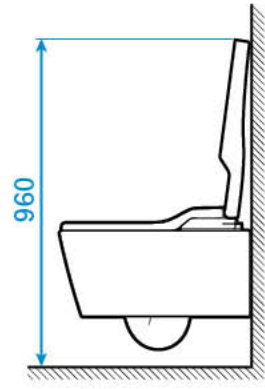
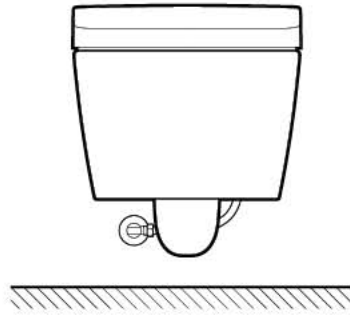
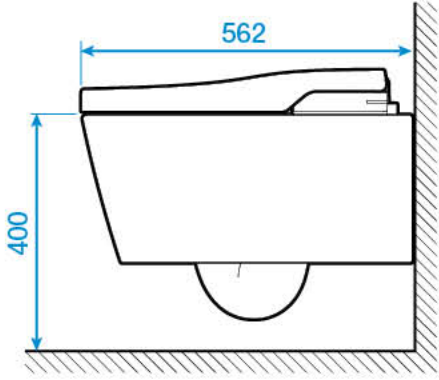

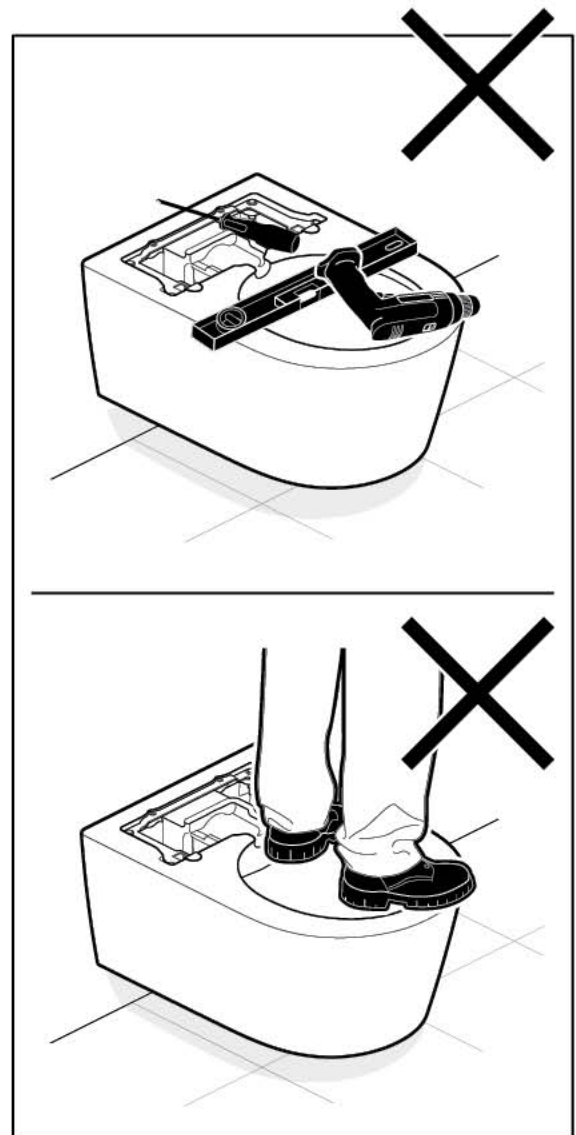
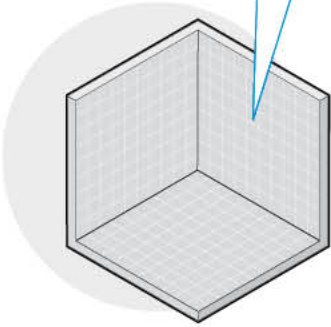
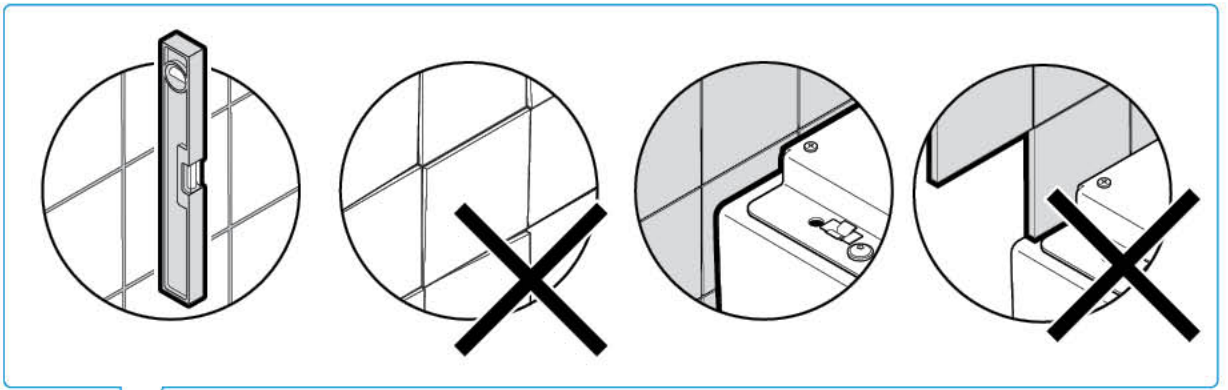



Instalación recomendada Recommended installation

Fijación
Fixation

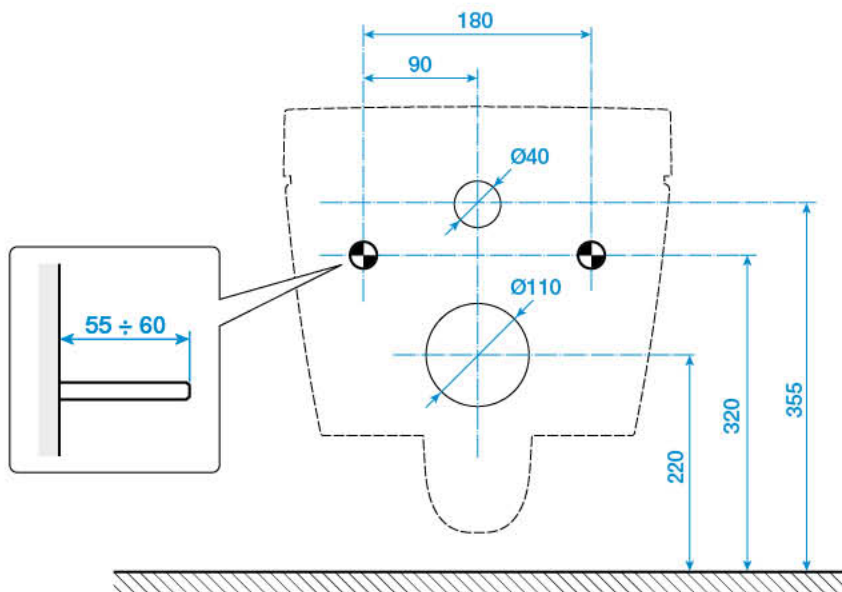

Recomendado
Recommended

Ejemplo de instalación
Installation example

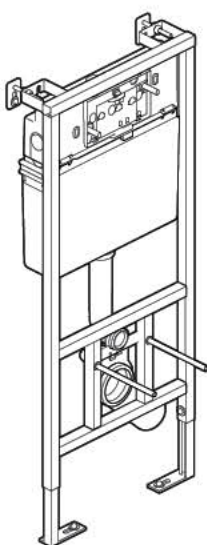

A890090000

A890080000

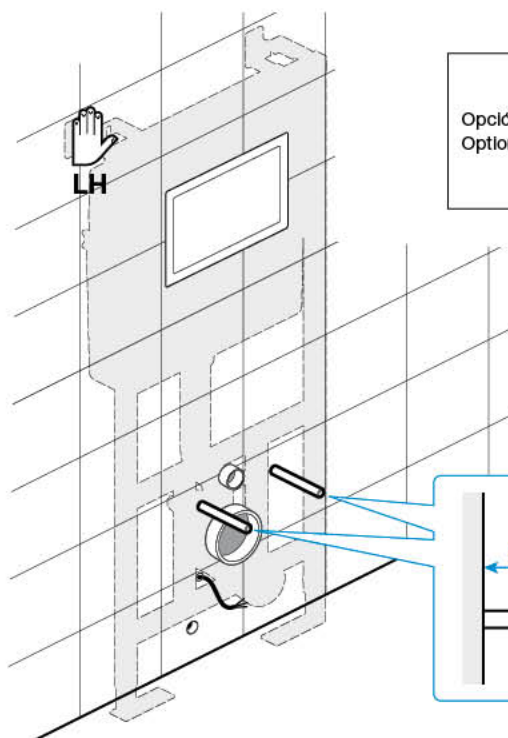

Opción
Option

1a
2a

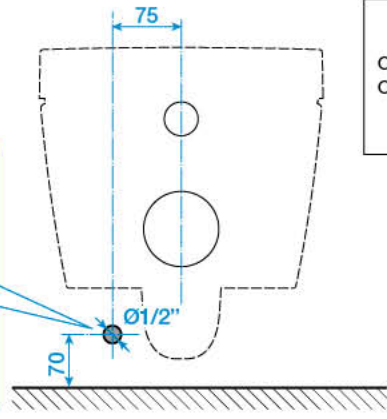
1**Conexión hidráulica**
PipesOpción
Option**1a**

[mm]

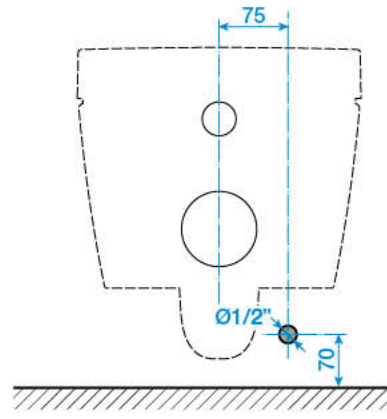
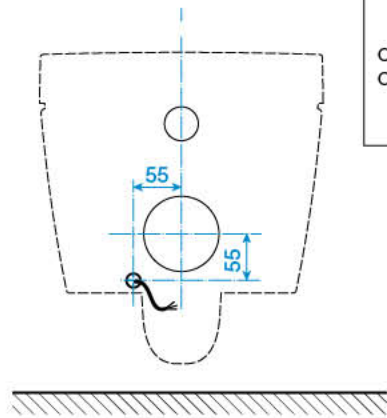
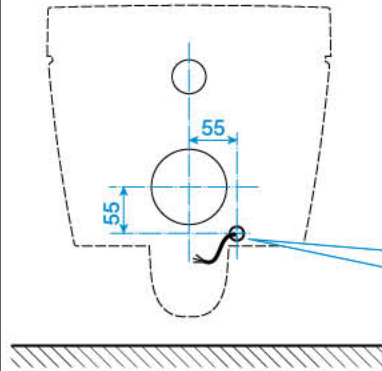
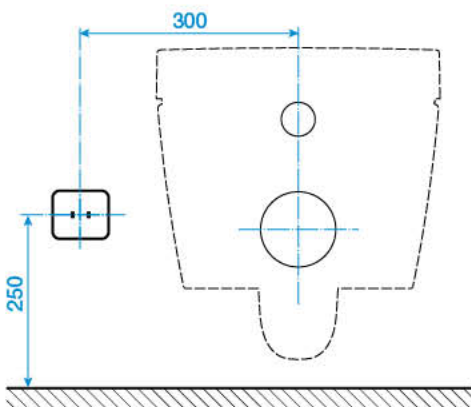
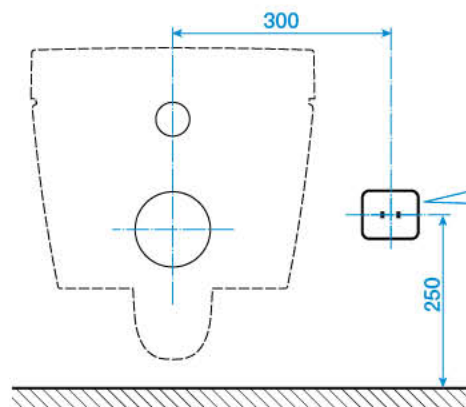
Opción
Option**1b****2****Conexión eléctrica**
ElectricalOpción
Option**2a**Opción
Option**2b**Opción
Option**2c**Opción
Option**2d**

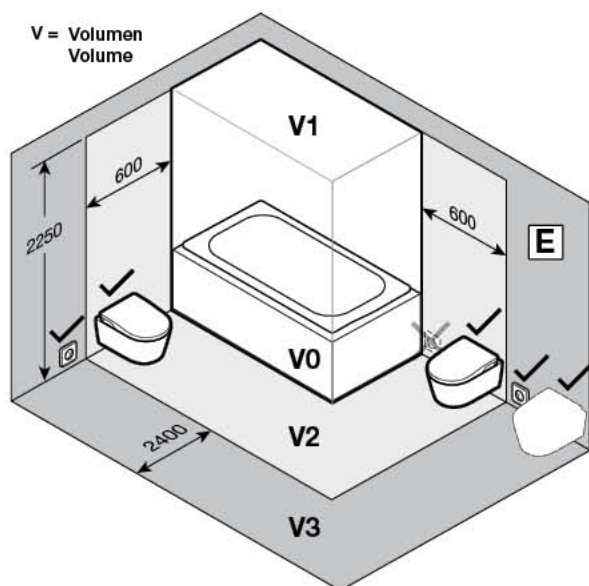
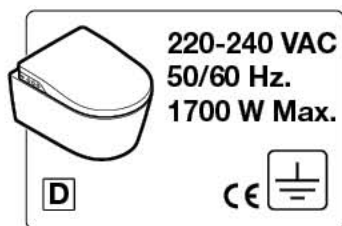
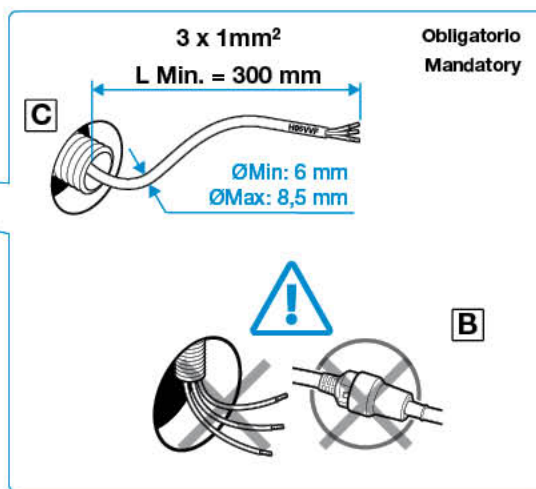
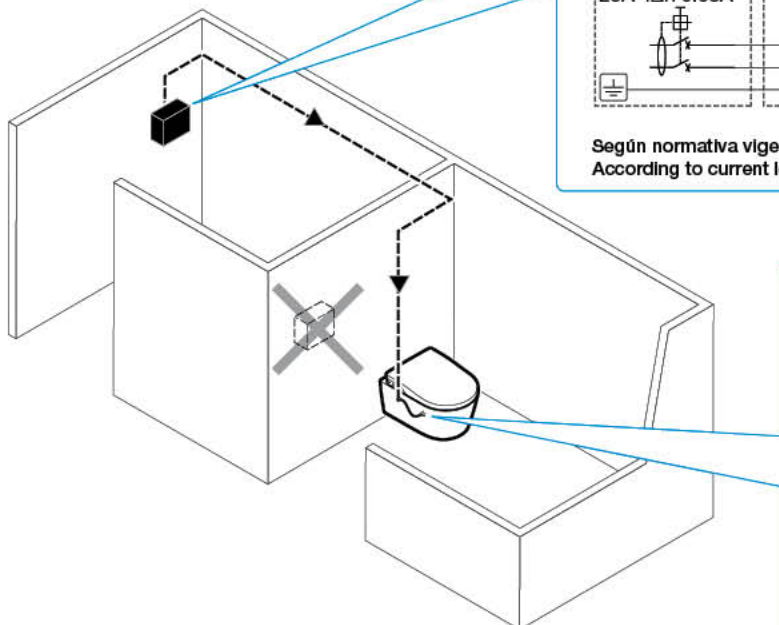
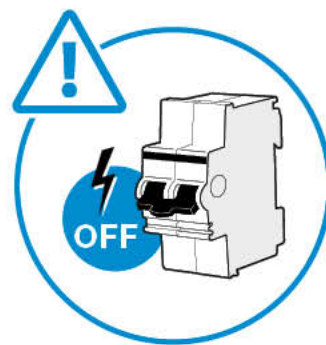
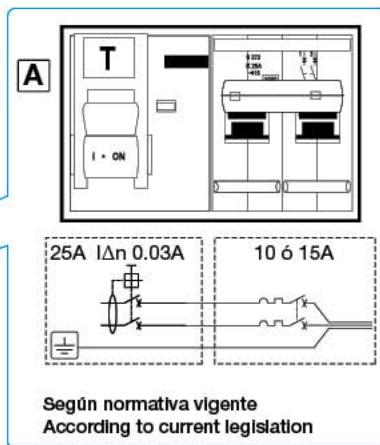

Este WC eléctrico puede instalarse en el volumen 2 aunque su toma de corriente o base de enchufe debe estar siempre instalada en el volumen 3.

Esta recomendación es válida siempre y cuando la normativa vigente en el país lo permita.

Este producto (IPX4) no debe estar sometido a ráfagas de agua para su limpieza.

This electric toilet may be installed in zone 2 although its wall-socket shall always be installed in zone 3.

These recommendations are valid as long as the installation is compatible with the country regulations.

This product (IPX4) shall not be exposed to water jets for cleaning purposes.

- ES**
- A** La instalación eléctrica debe protegerse mediante un interruptor diferencial de IDn 0,03A y 25A de potencia y de un interruptor magnetotérmico de 10 ó 15A. situado fuera de los volúmenes del cuarto de baño.
 - B** La conexión de alimentación de este producto debe realizarse siempre mediante el conector suministrado, a una instalación fija o a un enchufe de pared .
 - C** La línea eléctrica a instalar debe ser manguera de tres conductores (fase, neutro, tierra) de mínimo 1mm² de sección exclusivamente dedicada al inodoro.
En caso de que por avería fuese necesaria la manipulación o sustitución del cable de alimentación del e-bidet, únicamente podrá ser realizado por el Servicio Técnico.
 - D** El rango de funcionamiento del inodoro es de 220-240V, 50/60Hz.
 - E** No se debe manipular ninguna conexión eléctrica del inodoro.
No se debe introducir ningún aparato eléctrico dentro del inodoro.
La instalación debe ser efectuada por personal cualificado, de acuerdo a la normativa nacional vigente.

- EN**
- A** The electrical installation must be protected by means of a IDn 0,03A and 25A differential switch and a magnetothermal switch of 10 or 15A. Both switches must be placed outside the bathroom.
 - B** The power connection of this product must be permanently connected to a fixed electricity line. Placement of a plug is not acceptable.
 - C** The electrical line to be installed must be a hose consisting on three drivers (phase, neutral, earth) of at least 1mm² of section exclusively dedicated to the WC. In the event that, due to failure, it is necessary to handle or replace the power cable, this must only be done by Technical Service staff.
 - D** The range of function of the WC is 220-240V, 50/60Hz.
 - E** Neither component nor connection of the WC must be operated.
No electrical device must be introduced inside the WC.
This product must be installed by qualified personnel, in according with the national current regulation.

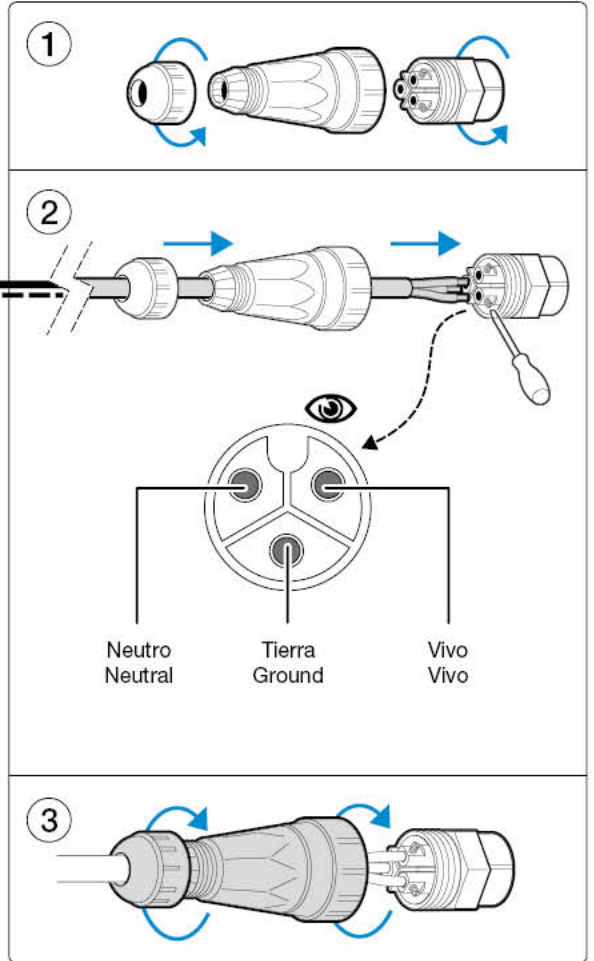
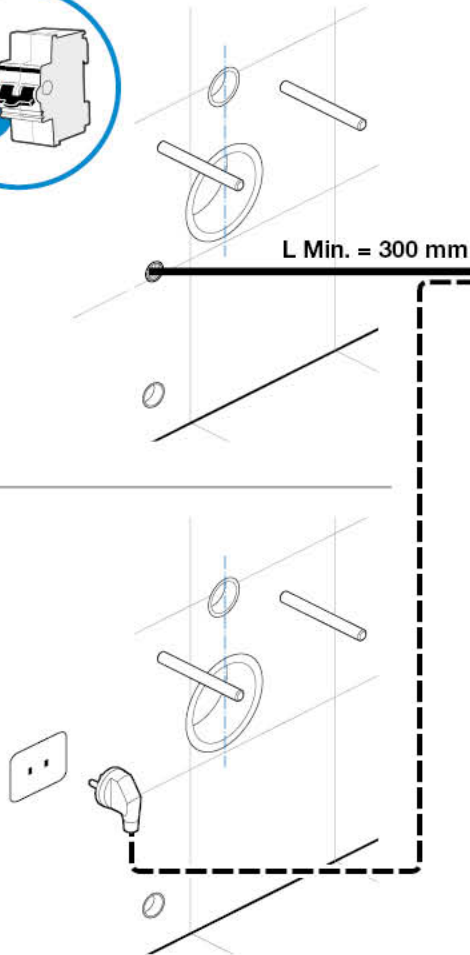
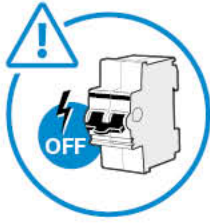
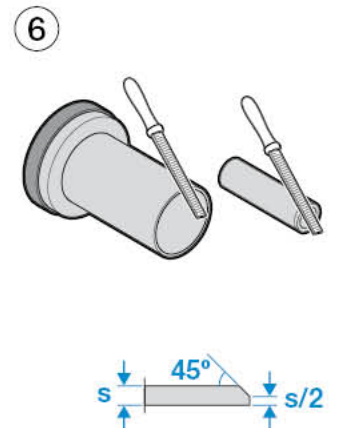
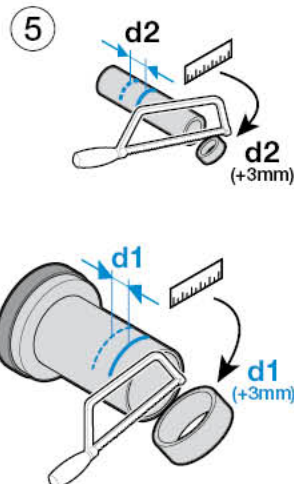
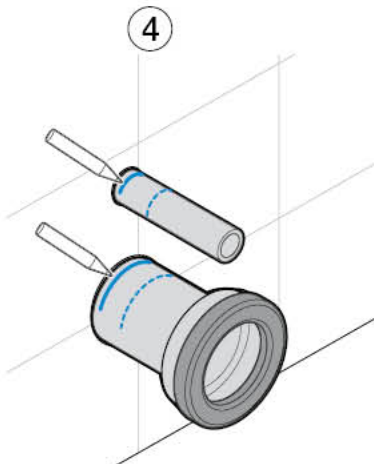
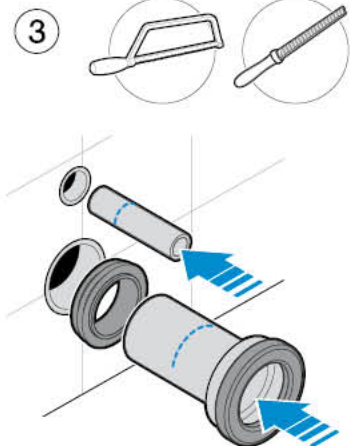
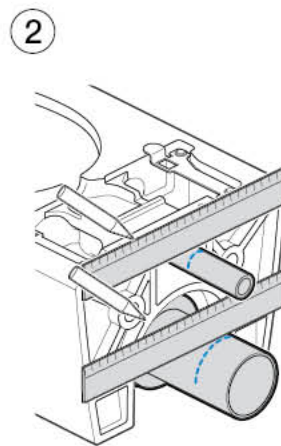
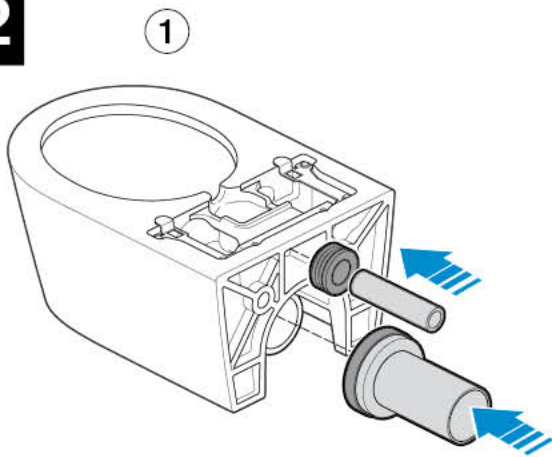
1**2**

3

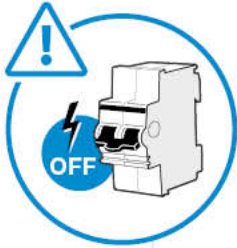

1

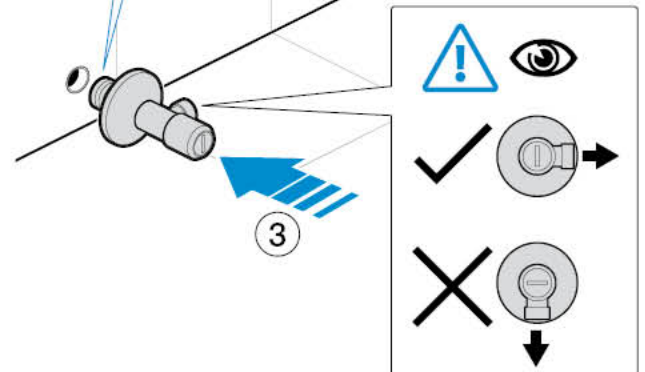
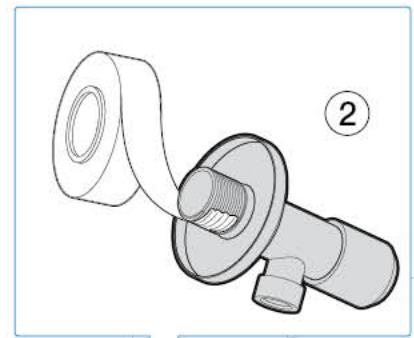
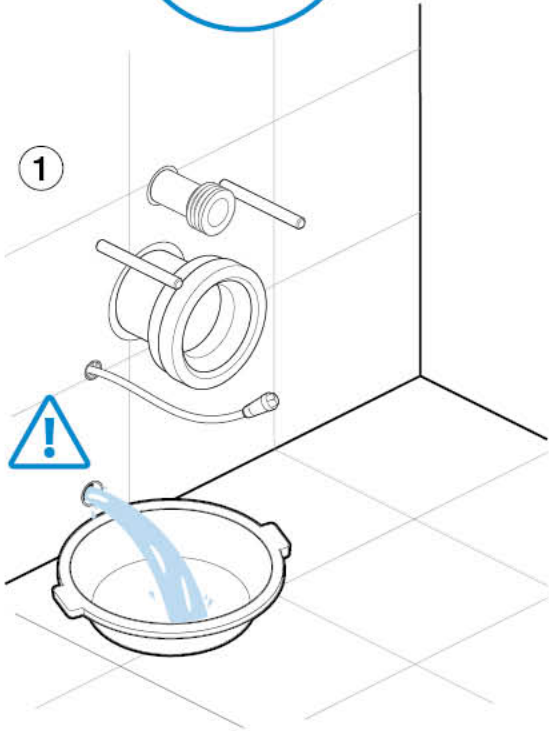

4

1

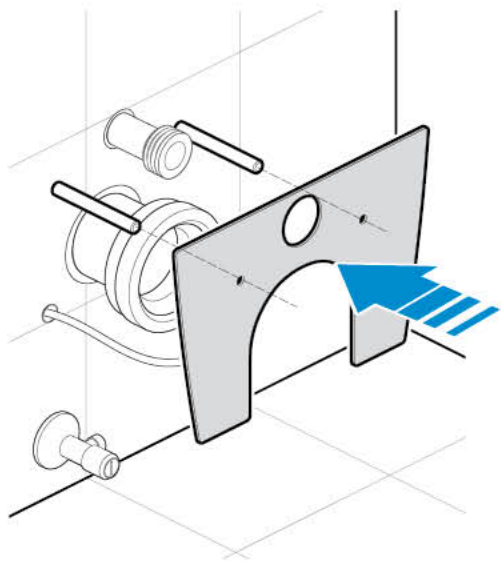

2

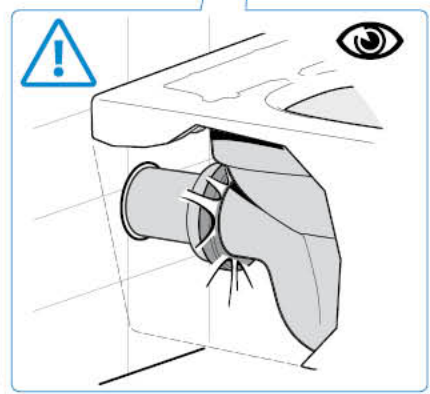
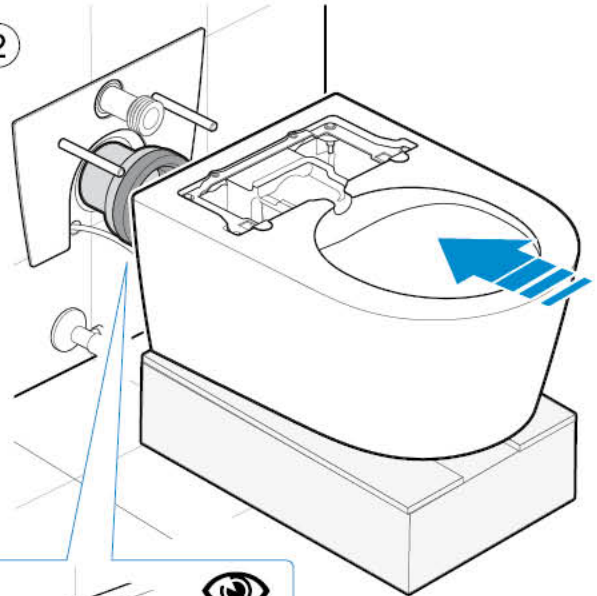

5

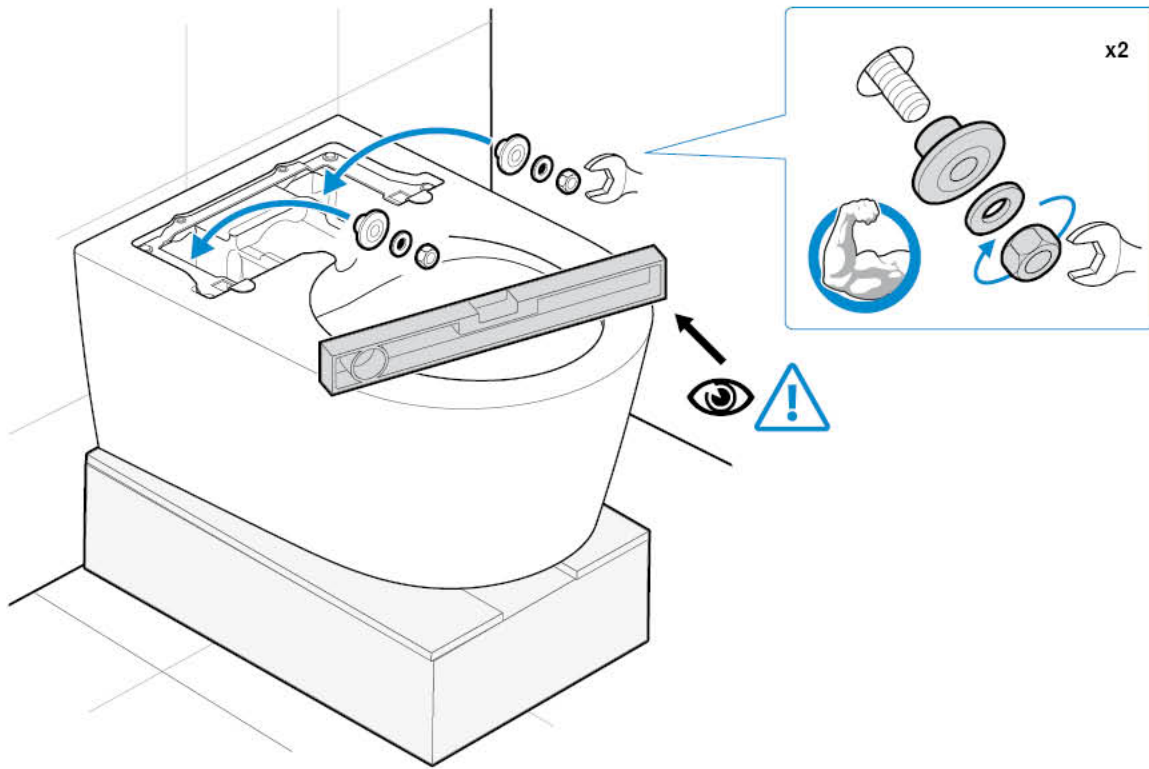

6

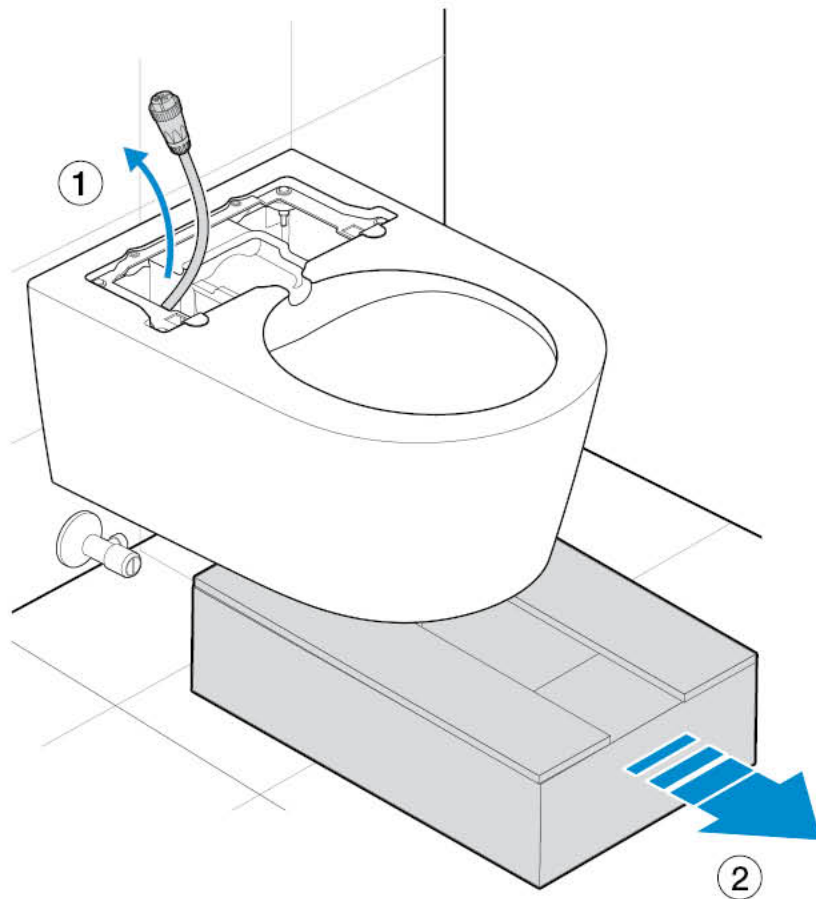

7

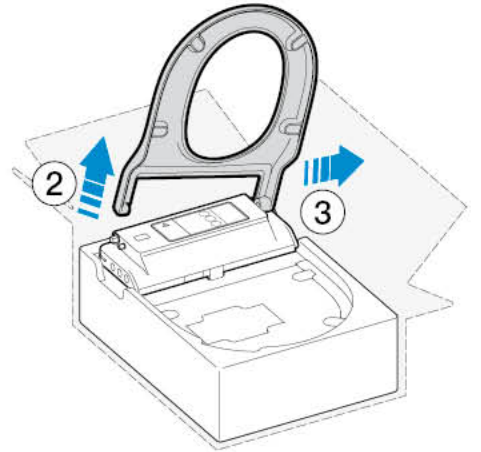
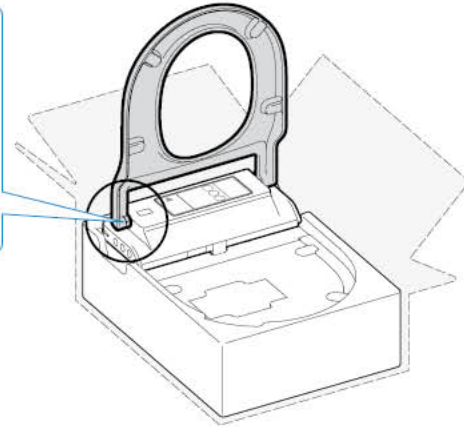
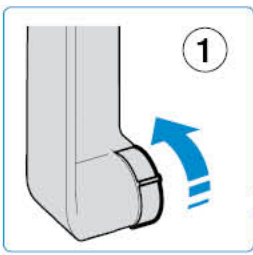
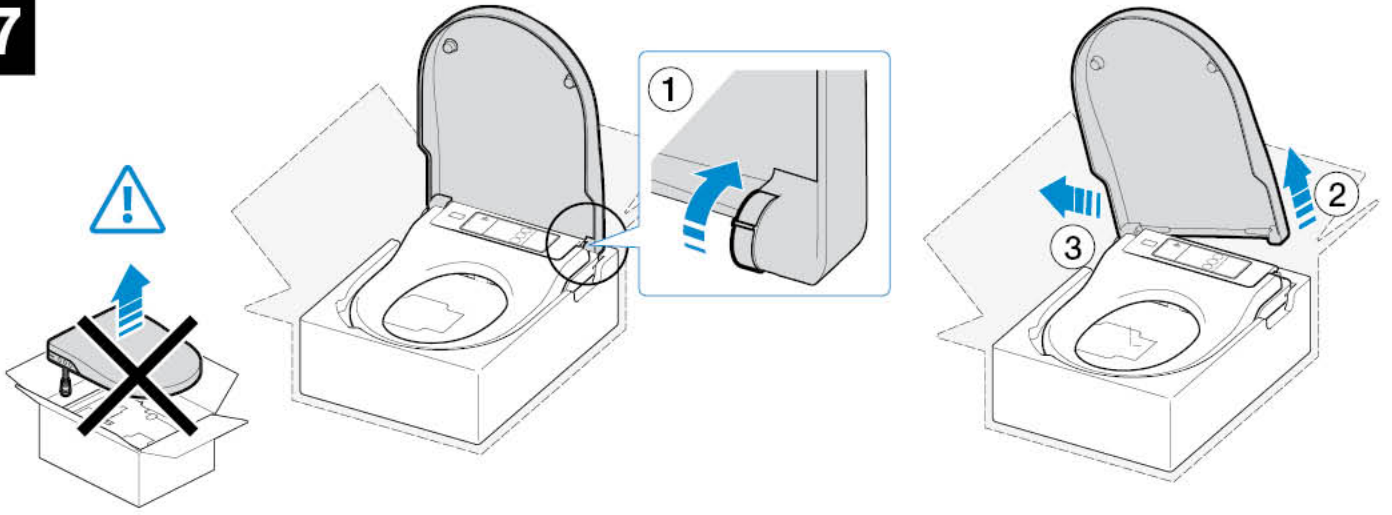

8

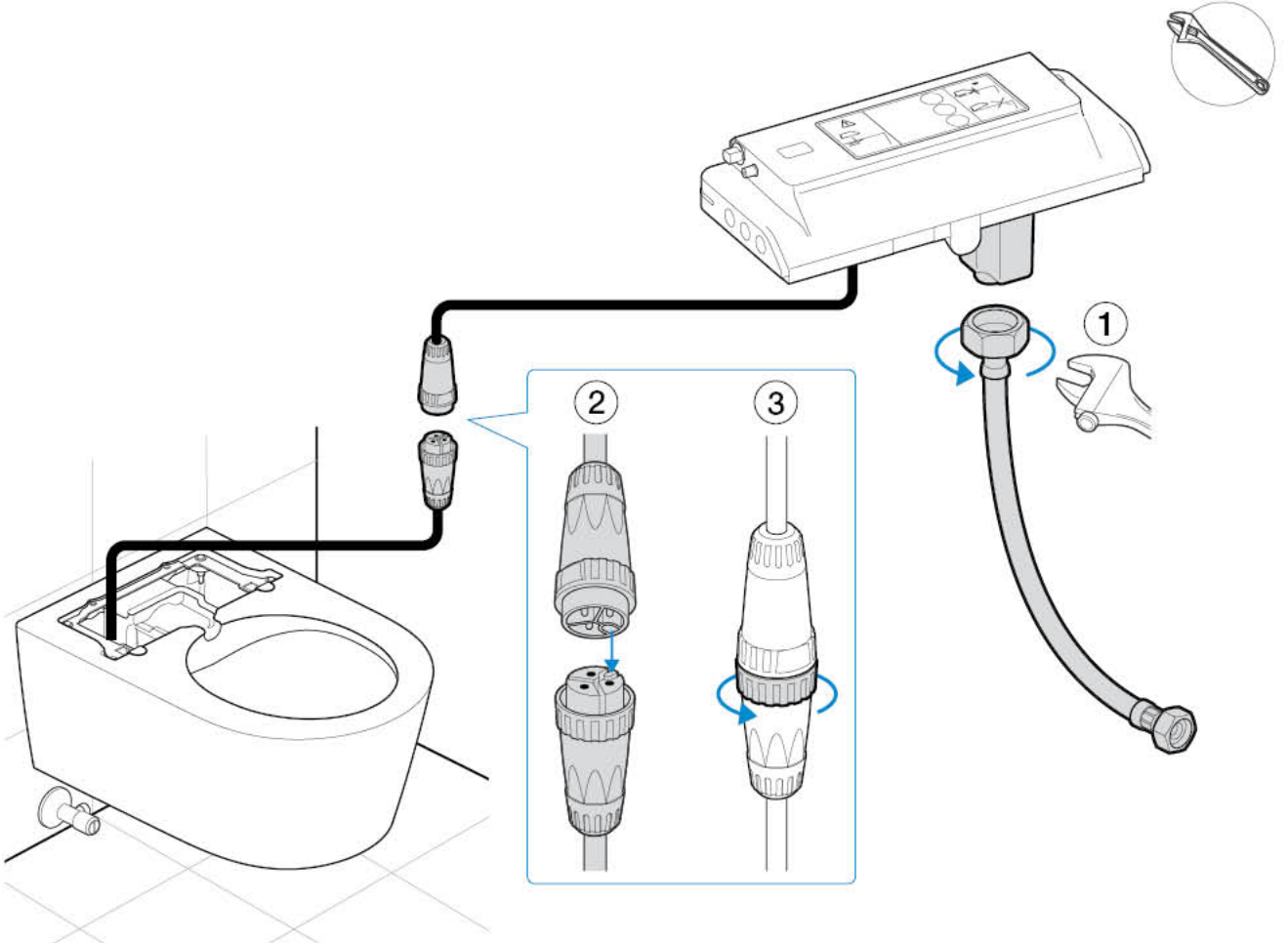

9

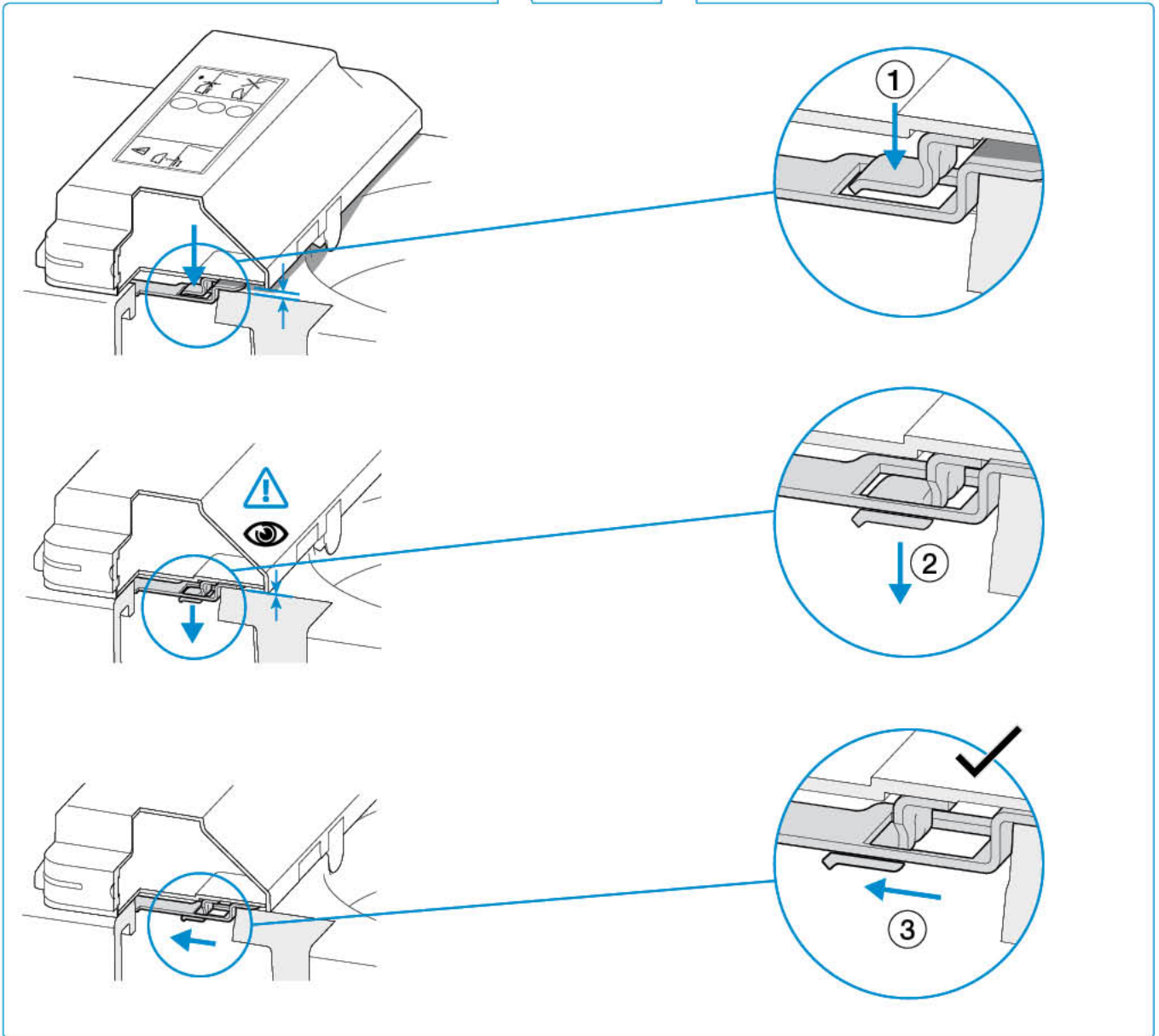
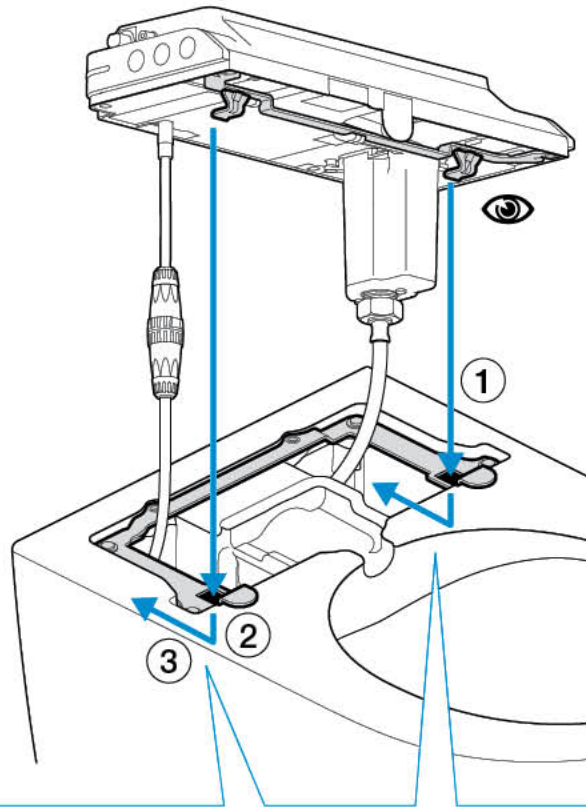

10

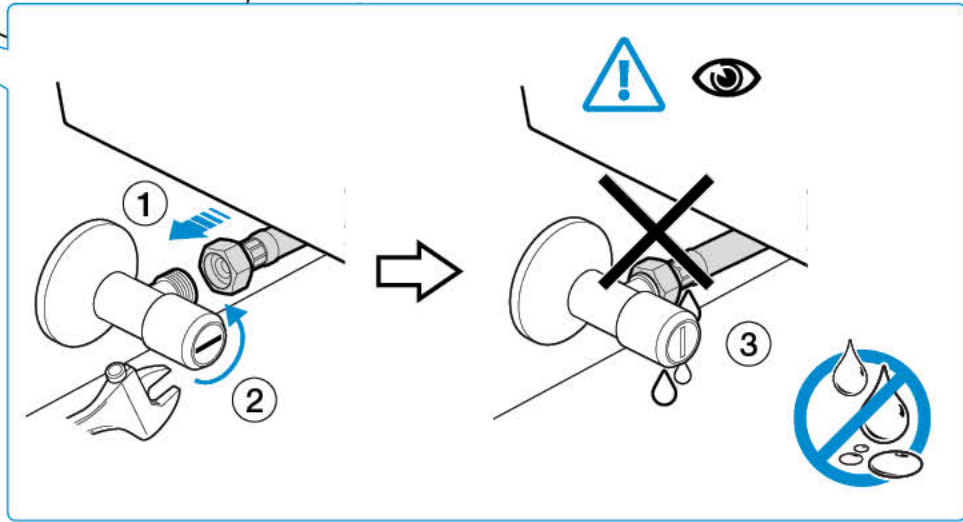
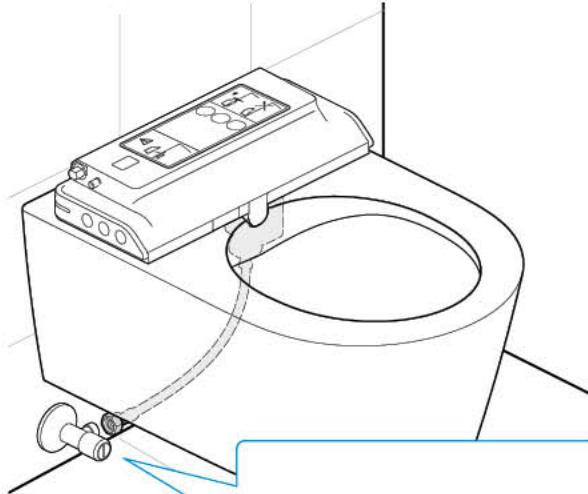

11

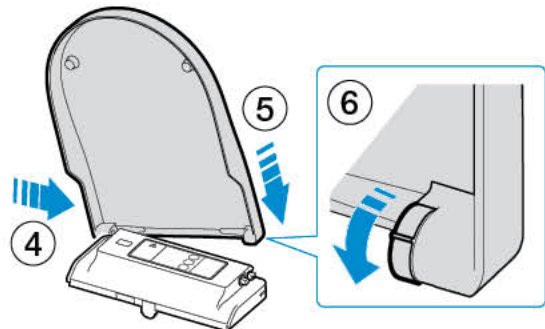
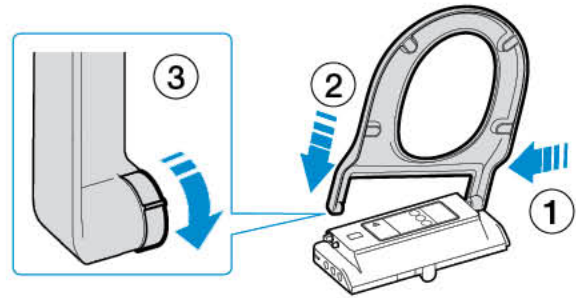
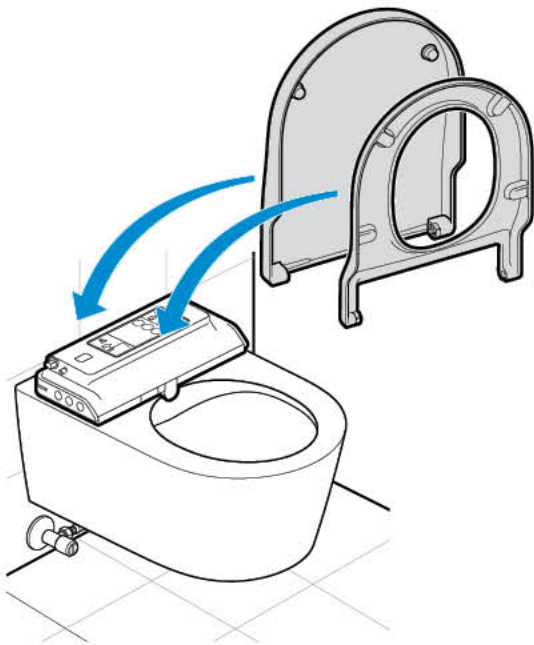

12

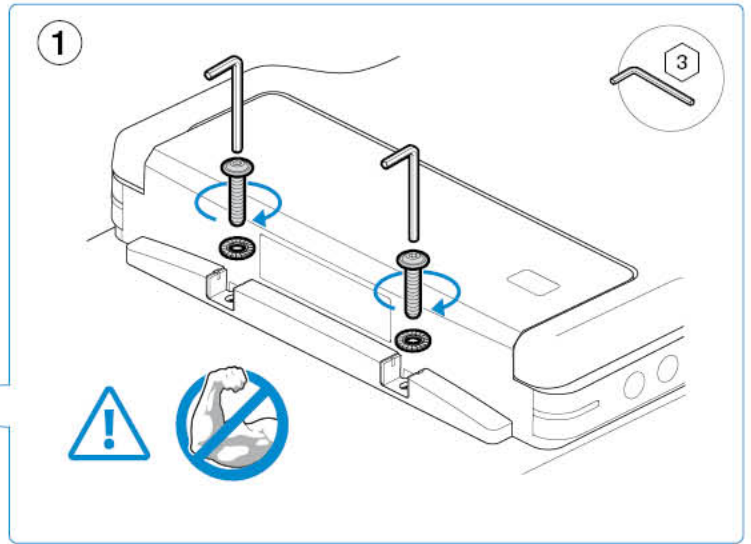
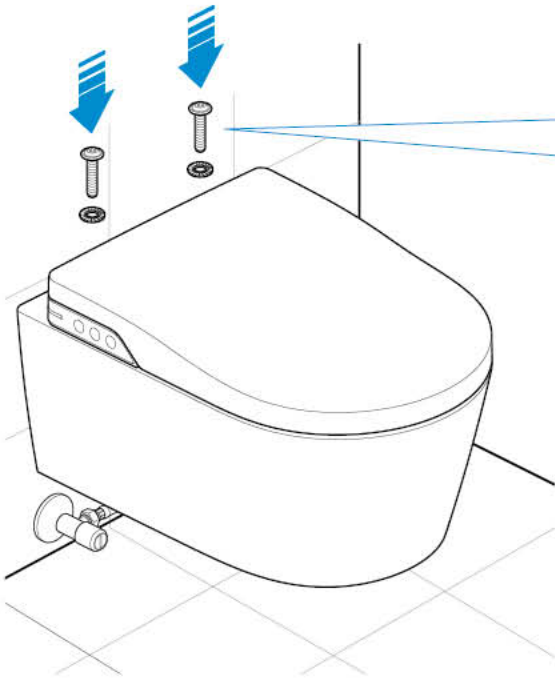

13

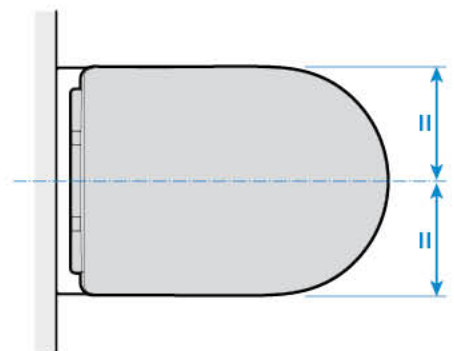
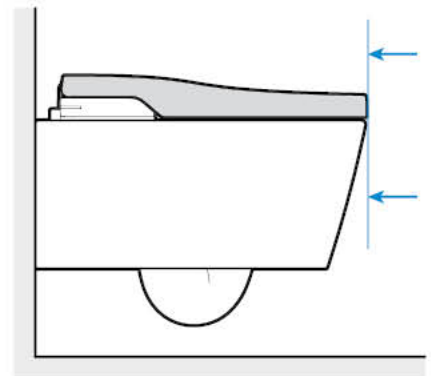
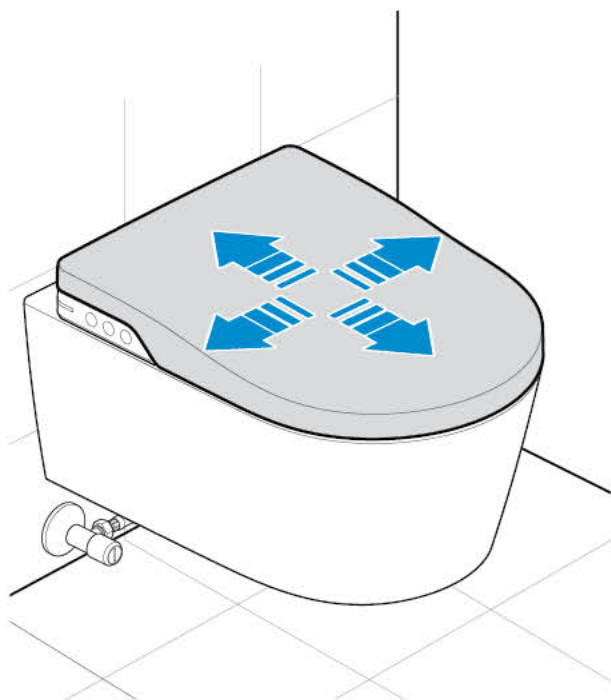

14

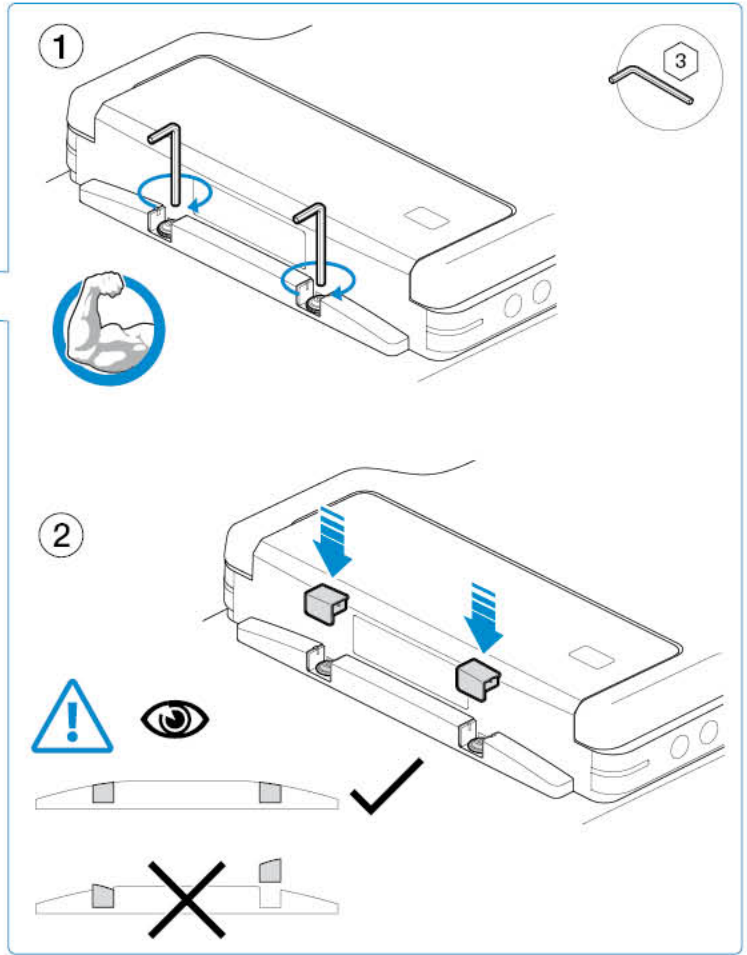
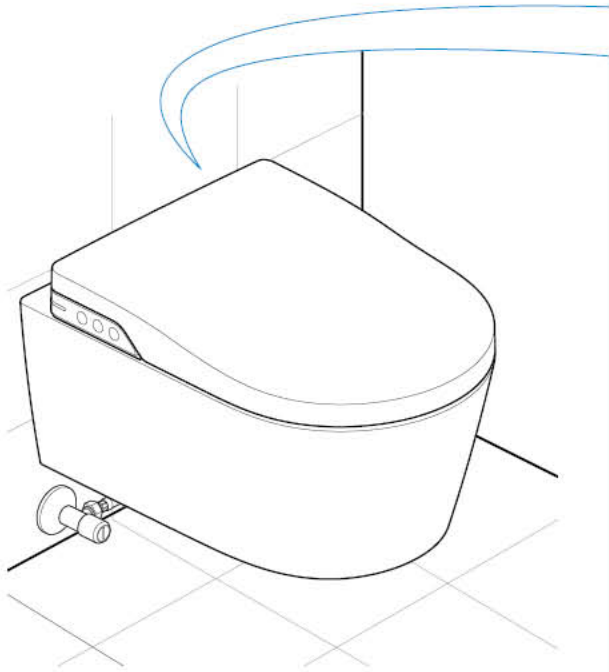

15

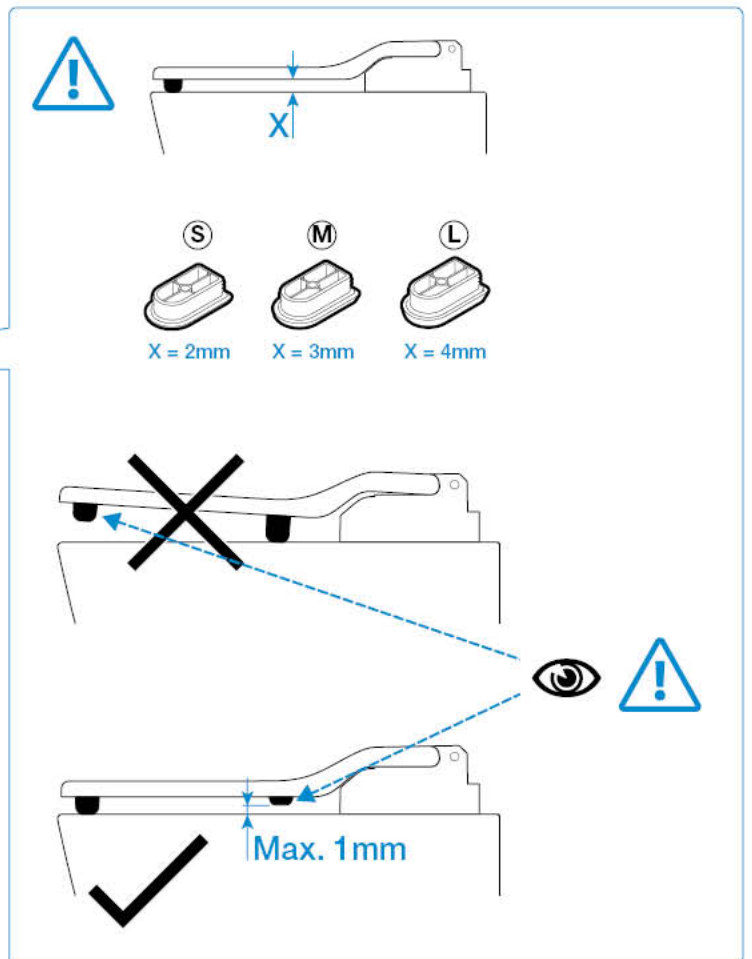
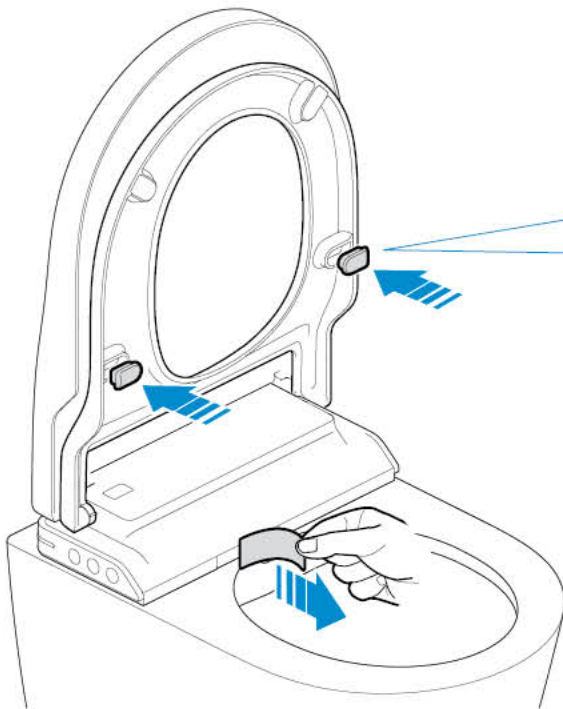

16

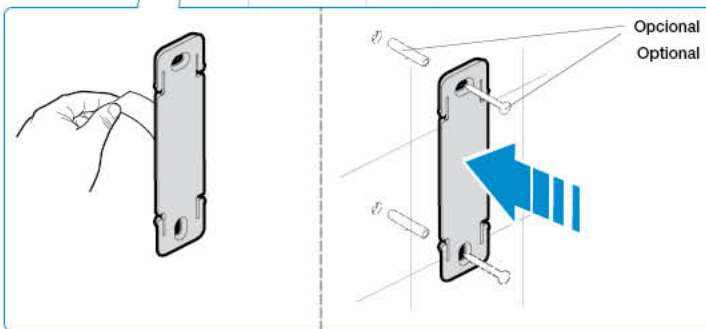
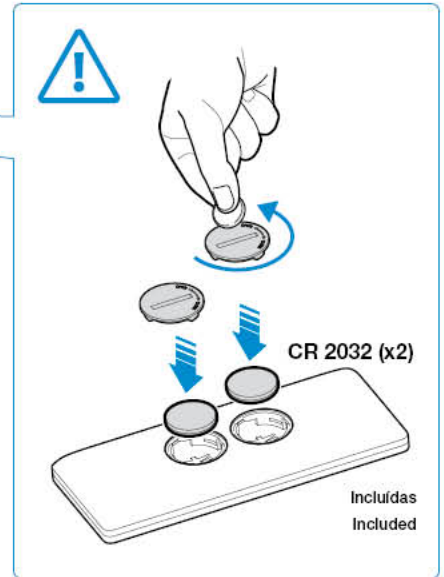
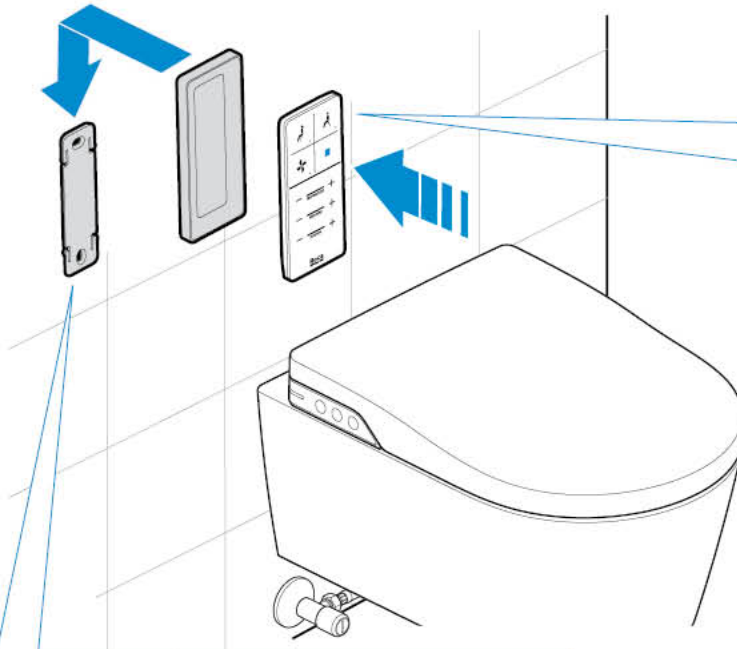

17

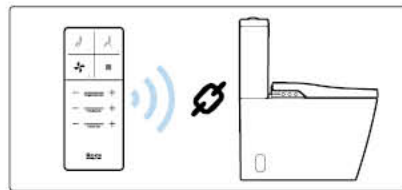

1 ABRIR AGUA
OPEN

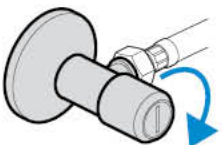

2 ENCHUFAR
POWER

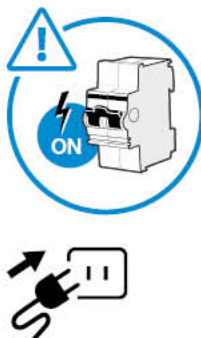

3 SINCRONIZAR
CONNECT

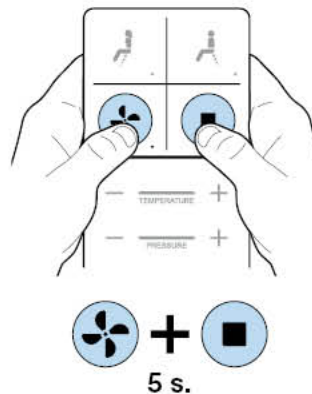

4 AUTO-CALIBRACIÓN
AUTO-TEST

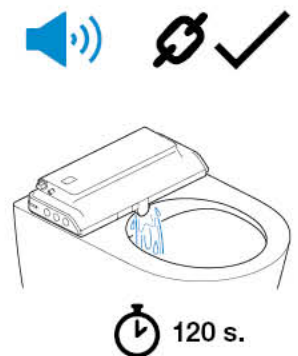

ES Desde el instante en que se enchufa el aparato a la red (2), se dispone de 60 segundos para sincronizar el mando. Para sincronizar el mando (3), presionar simultáneamente los botones Secado y Paro/Stop del mando durante 5 segundos hasta que se escuche un beep y se encienden todos los LED del mando. A partir de ese momento se inicia un proceso de auto-calibración del aparato (4) que dura 120 segundos, durante el cual sale agua por la ventana de la cánula del e-bidet.

EN After connecting the power (2), you have 60 seconds to link the remote control. To link the remote control (3), press simultaneously the Drying and Stop buttons on the remote control for 5 seconds. A beep will be heard and all the LEDs on the remote light up, as a signal that it is connected. A self-calibration process starts for 120 seconds (4) during which water flows from the e-bidet nozzle window.

18

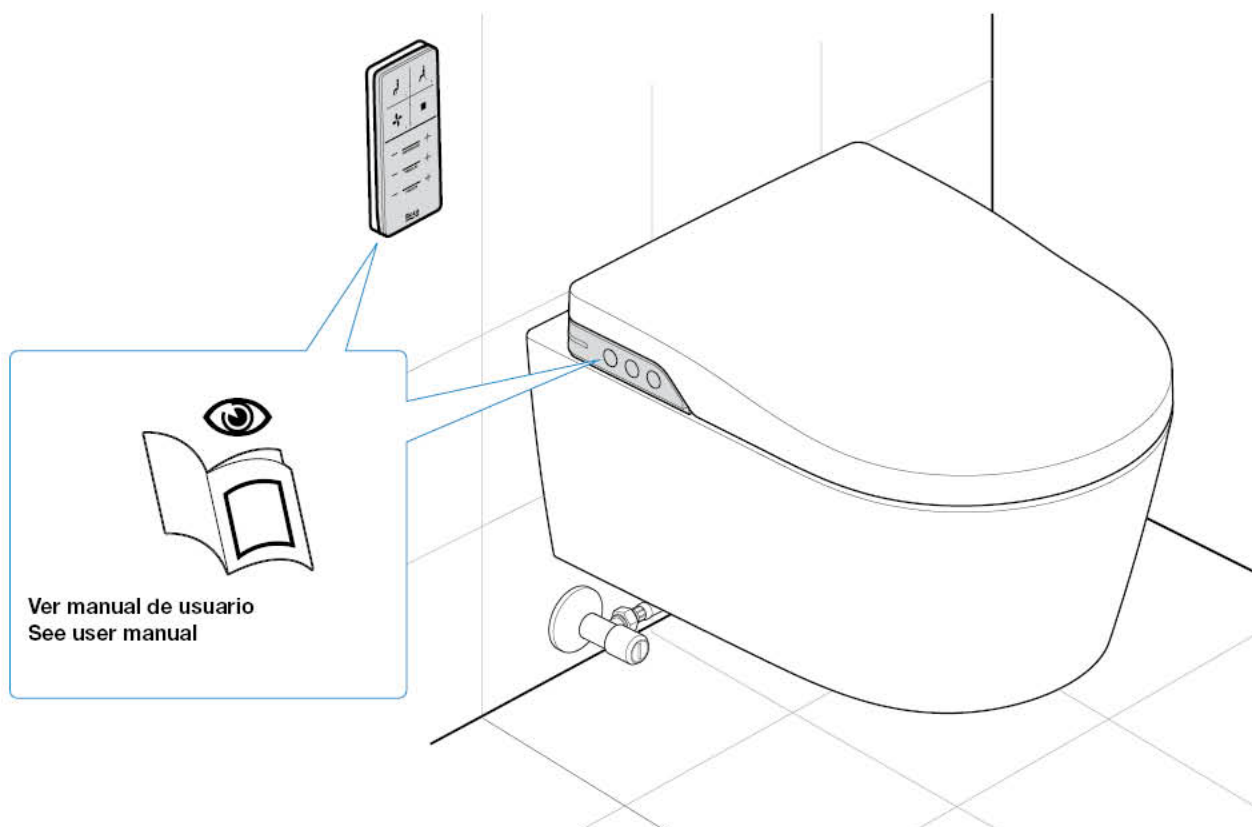



Roca Sanitario, S.A.
Avda. Diagonal, 513
08029 Barcelona
SPAIN
www.roca.com

**902
304
848** 
LÍNEA DE
ATENCIÓN AL
CONSUMIDOR
ESPAÑA

**902
400
423** 
SERVICIO
TÉCNICO
ESPAÑA

productsupport.rs@roca.net
soporteproducto.rs@roca.net